



UNDER TAILGATE SPREADER

VCT 11 & 12

HINGED LOWER SECTION FOR EASY CLEAN OUT



Lower section and cover plate held in place by latch bolts with handles. 6" continuous flite auger is standard feature of the VCT 11 spreader machine. The VCT 12 offers a reverse flited auger which pulls material from the left as well as the right side of load. Both units have a baffle plate over discharge opening to prevent loss of material when machine is not running.

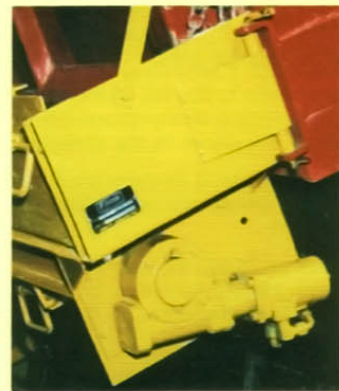

OPTIONAL GEAR BOX
DRIVE UNIT, VCT 12G

Manufactured By Flink • 502 N. Vermillion St. • Streator, IL 61364
ORIGINATOR OF TAILGATE SPREADERS AND HYDRAULICALLY DRIVEN SPREADERS



DESIGN FEATURES

VCT 11 & 12

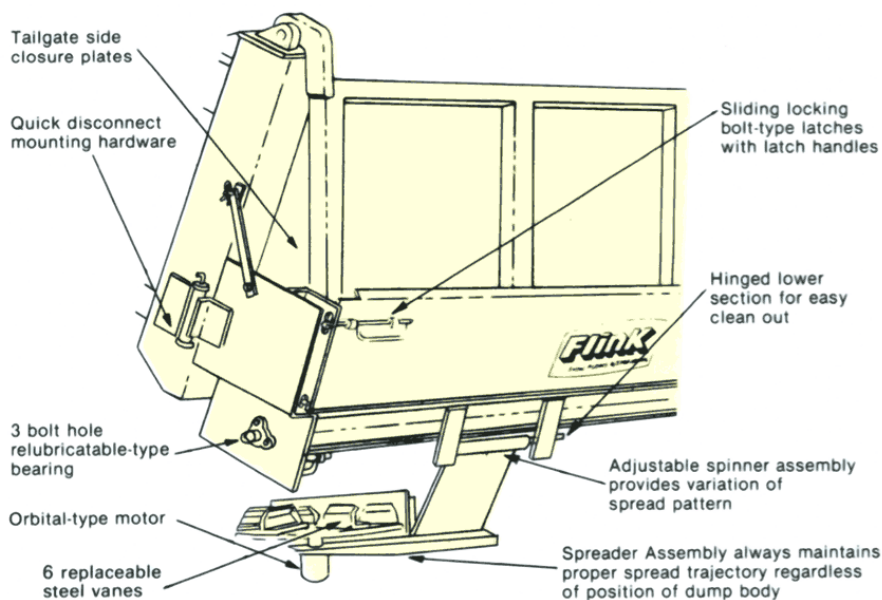

OPTIONS AVAILABLE

URETHANE SPINNER:

Will not rust or corrode. More effective material dispersal with less waste.

SHORT HOSE KIT:

Includes quick disconnects at rear of truck and hoses from spreader motors to rear of truck.

DUAL FLOW CONTROL VALVE:

Valve allows infinite variable feed rate independent of truck speed.

SPECIFICATIONS

GENERAL:

Spreader mounts on rear of dump body below regular dump box tailgate in a manner to allow use of dump body with spreader attached. Tailgate may be hinged at top or at the bottom.

TROUGH:

The trough is constructed of #7-gauge steel. End plates are 1/4" steel. Rear wall reinforcement channel of #7-gauge steel 3 5/8" x 1 11/16" extending the length of the trough and welded to the end plates. The trough design shall incorporate the easy clean-out feature which is of a hinged trough floor and rear wall. The hinged floor shall swing clear of the auger to allow material to fall through the auger area and simplify the removal of any blockage. Trough is 16" front to back, 95 5/8" long, and 19 1/4" high. Entire unit is electric welded throughout.

Locking Device - Positive sliding locking bolt-type latches with latch handles. Hand grip handles are constructed of 1/2" formed steel rod. Easy open handles, no tools required, permanently attached to eliminate loss.

TROUGH COVER PLATE:

Type - The cover plate is the full width, full length type hinged design to permit dumping of any material over the spreader with no accumulation of material in the spreader trough.

Design - The cover plate is dual-purpose design incorporating a portion of the rear trough wall/spill plate. Minimum #10-gauge steel shall be used.

Operation - The cover plate is hinge mounted for easy one-man positioning to both the open and closed positions and is designed for easy removal from the spreader without tools.

FEED AUGER:

VCT 11 - The feed auger is a continuous 6" auger with continuous pitch. Single auger constructed of 2 3/8" O.D. x 5/32" wall. Flite thickness shall be 3/8". Discharge shall be at the left end of the trough.

VCT 12 - The feed auger is a 6" auger with continuous pitch. Single auger shaft is constructed of 2 1/2" pipe. Flite thickness shall be 3/8". Left end of auger has reverse flighting to deliver material from left end of trough assembly to discharge opening.

SPECIFICATIONS SUBJECT TO CHANGE WITHOUT NOTICE.

Auger Bearings - The auger is mounted in 1 1/4" sealed, self-adjusting, ball bearings. Bearings are mounted in the trough end sections in three bolt flange supports.

Auger Drive - The feed auger is driven by a hydraulic motor through a gear and chain reducer. The chain is enclosed in a protective cover with an easily removable cover using a positive bolt-type latch for locking.

ANTI-FLOW PLATE:

An anti-flow plate covering the trough discharge hole above the auger shall be provided to prevent material flow when the auger is not turning. The anti-flow plate is easily removed for clean-out without tools.

TRUCK MOUNTING HARDWARE:

The spreader trough mounts to the truck dump body, utilizing single pin "quick-detach" hardware.

SPINNER ASSEMBLY:

The spreader is equipped with a direct hydraulic drive, single disc, distributing spinner assembly.

Design - The spinner is designed to evenly distribute material over an adjustable width of 4 feet to 40 feet. There is a self-leveling device to keep the spinner disc parallel to the road at any dump body angle. A deflector shield to the rear of the spinner is furnished. The spinner mounting shall be adjustable to provide for variation of spread width and direction. The complete spinner assembly is designed for easy one-man mounting and removal from the spreader trough without tools.

Construction - The spinner assembly shall be all-steel construction. The disc is 18" in diameter with 6 #7-gauge steel vanes.

HYDRAULIC MOTORS:

The hydraulic motors are a standard gerotor design and mount.

Sales and Service By: